



# 2U Multi-display Console Drawer



### Key Benefits

- ▶ 2U 22" short depth design
- ▶ Light weight
- ▶ Rugged construction for mobility & durability
- ▶ Built-in solid bearing slide rails
- ▶ Built-in dual stereo speaker ( per display )
- ▶ Four LED backlit display selections ( 4K, WUXGA, FHD, 4:3 )
- ▶ DVI-D + VGA video input for WUXGA, FHD & 4:3 ( per display )
- ▶ Display port 1.2 video input for 4K ( per display )
- ▶ 104-key keyboard with either touchpad or trackball ( PS2 / USB )
- ▶ Fits 24" ~ 36" rack via adjustable mounting brackets
- ▶ 2-year standard warranty ( upgradable up to 5 years )
- ▶ TAA Compliant



### Options

- DC power : 12V / 24V / 48V / 125V / 250V
- 3G / HD / SD-SDI Broadcast-grade input
- Sunlight readable LCD for 17" FHD & 19" 4:3
- Touchscreen
- Front USB hub port for device access
- HDMI video input
- MAC or SUN Micro keyboard
- USB keyboard & mouse selector

The MRK 2U dual or triple display console drawer is designed for Command and Control Systems which demand quick deployment of side by side displays.

2U 22" depth platform allows for small size and transit case portability. To ensure chassis ruggedness, mobility and quality, as well as being suitable for harsh environment applications, the MRK drawer is meticulously constructed by a team of experts in our own CNC facilities for such applications.

The key benefit of the MRK series is the choice of different resolution panels including 4K 17", WUXGA 16.2", FHD 17" 60Hz, 19" 4:3 LED backlit displays. Sunlight Readable FHD 17" LCD is also available. 4K 17" displays satisfy the increasing demands for higher graphical and text requirements. A solid 104 key keyboard is integrated with either touchpad or trackball.

## Models

LH mounted



RH mounted



17"



MRK-K17-2L

MRK-K17-3

MRK-K17-2R

17"



MRK-F17-2L

MRK-F17-3

MRK-F17-2R

16.2"



MRK-X17-2L

MRK-X17-3

MRK-X17-2R

19"



MRK-19-2L

MRK-19-3

MRK-19-2R

## Product Specifications

LCD Panel	MRK-K17	MRK-F17	MRK-X17	MRK-19
Native resolution	3840 x 2160@60Hz	1920 x 1080	1920 x 1200	1280 x 1024
Panel size (diagonal)	17.3"	17.3"	16.2"	19"
Refresh rate (Hz)	60	60	60	60 / 75
Standard Brightness (cd/m <sup>2</sup> )	400	300	300	250
High Brightness (cd/m <sup>2</sup> ) - Option	/	1000	/	1000
Contrast ratio (typ.)	1000 : 1	1000 : 1	800 : 1	1000 : 1
Colors	16.7 M, 8-bit	16.7 M, 8-bit	16.7 M, 8-bit	16.7 M
Viewing angle (L/R/U/D)	89/89/89/89	85/85/85/85	89/89/89/89	85/85/80/80
Response time (ms)	Max. 16	25	30	5
Dot pitch (mm)	0.0995	0.1989	0.191	0.294
Display area (mm)	382.12H x 214.94V	381.888H x 214.812V	383.8H x 214.9V	337.92H x 270.33V
Surface treatment	Anti-glare	Anti-glare, Hard-coating	Anti-glare, Hard-coating	Haze 25%, Hard-coating
Surface hardness	3H			
Backlight type	LED			
MTBF (hrs)	15,000	15,000	20,000	30,000

Video	MRK-K17	MRK-F17	MRK-X17	MRK-19
Package	DP 1.2 / HDCP 1.3 <i>* attached 6ft DP cable</i>	DVI-D + VGA	DVI-D + VGA	DVI-D + VGA
Option	HDMI 2.0 / HDCP 2.2	HDMI 1.4 / HDCP 1.4 or DP 1.0 / HDCP 1.3	HDMI 1.4 / HDCP 1.4	HDMI 1.2 / HDCP 1.1

## Capacitive Touch screen Option

	MRK-K17	MRK-F17	MRK-X17
Technology	Projected Capacitive		
Touch Point	10 point touch standard		
Input Type	Finger or Capacitive Stylus		
Resolution	4096 x 4096		
Touch Point Accuracy	± 2 mm		
Response Speed	< 5 ms		
Activation Force	< 5 g		
Surface Hardness	6H		
Light Transmission	> 85%		
Haze	3%↓		
Durability	50 million touches		
Top Layer	1.8 mm Glass		
Bottom Layer	0.7 mm Sensor Glass		
Thickness	2.7 mm ± 0.1 mm		
Connector	USB		
Compatibility	Windows 7 / XP / Linux / Mac		

## Resistive Touch screen Option

	MRK-K17	MRK-F17	MRK-X17	MRK-19
Technology	5-Wire Resistive			
Touch Point	Single			
Input Type	Finger or Stylus			
Resolution	2048 x 2048			
Response Speed	15 ms			
Activation Force	≤ 50 g			
Surface Hardness	3H			
Light Transmission	80% ± 3%			
Haze	8% ± 3%			
Durability	10 million touches			
Top Layer	ITO Film			
Bottom Layer	ITO Glass			
Thickness	3.2 ± 0.2 mm	2.2 ± 0.2 mm	3.2 ± 0.2 mm	2.2 ± 0.2 mm
Connector	USB Type A			
Compatibility	Windows 7 / XP / Linux / Mac			

## Product Specifications

Power		MRK-K17	MRK-F17	MRK-X17	MRK-19
Input		Auto-sensing 100 to 240VAC, 50 / 60Hz			
Consumption per panel	Screen on	Max. 21W	Max. 14W	Max. 25W	Max. 22W
	Power saving	Max. 2W			
	Power button off	Max. 1W			

Physical			
Product (W x D x H)	MRK-K17 / MRK-X17 / MRK-F17	mm inch	441.6 x 550 x 88 17.4 x 21.7 x 3.5
	MRK-19	mm inch	441.6 x 600 x 88 22.8 x 23.6 x 7.8
Packing (W x D x H)	MRK-K17 / MRK-X17 / MRK-F17	mm inch	580 x 683 x 197 22.8 x 26.9 x 7.8
	MRK-19	mm inch	581 x 753 x 216 22.9 x 29.7 x 8.5
Net Weight	MRK-K17 / MRK-X17 / MRK-F17	Triple display Dual display	25.7 kg / 56.5 lb 21 kg / 46.2 lb
	MRK-19	Triple display Dual display	26.7 kg / 58.7 lb 22 kg / 48.4 lb
	MRK-K17 / MRK-X17 / MRK-F17	Triple display Dual display	31.1 kg / 68.4 lb 26 kg / 57.2 lb
Gross Weight	MRK-K17 / MRK-X17 / MRK-F17	Triple display Dual display	31.1 kg / 68.4 lb 26 kg / 57.2 lb
	MRK-19	Triple display Dual display	32.1 kg / 70.6 lb 27 kg / 59.4 lb
Chassis color		Dark	
Chassis materials		Steel	

\* All dimensions stated are subject to change if options are selected / integrated to base model part codes

Compliance	
EMC	FCC & CE
Safety	CE / LVD & UKCA
Environment	REACH & RoHS3 / WEEE

Environment	
Operating temp.	0 to 55°C degree
Storage temp.	-20 to 60°C degree
Operating humidity	10~90%, non-condensing
Storage humidity	5 ~90%, non-condensing
Operating altitude	16,000 ft
Non-operating altitude	40,000 ft
Shock	10G acceleration ( 11ms duration )
Vibration	10~300Hz 0.5G RMS random vibration

## USB Keyboard & Mouse Selector

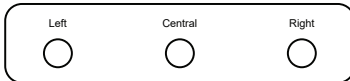

- Enables 2 or 3 computers to share keyboard & mouse.
- Easily switch to any of your connected computers with the press of a button

## Standard Keyboard

**Ge** G keyboard with touchpad

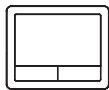
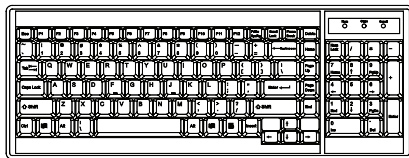

**Gb** G keyboard with trackball

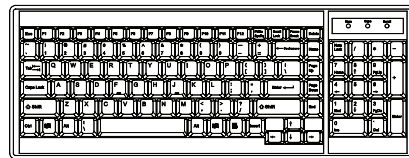

### Supporting layouts

America		U.S.
EMEA		U.K.
		Germany
		France
		Russia
		Spain
Asia		Japan
		Korea

## Keyboard Options

\* US layout only

**Me** Mac keyboard with touchpad



**Se** S keyboard with touchpad

**Mb** Mac keyboard with trackball

**Sb** S keyboard with trackball



# Diagrams ( mm )

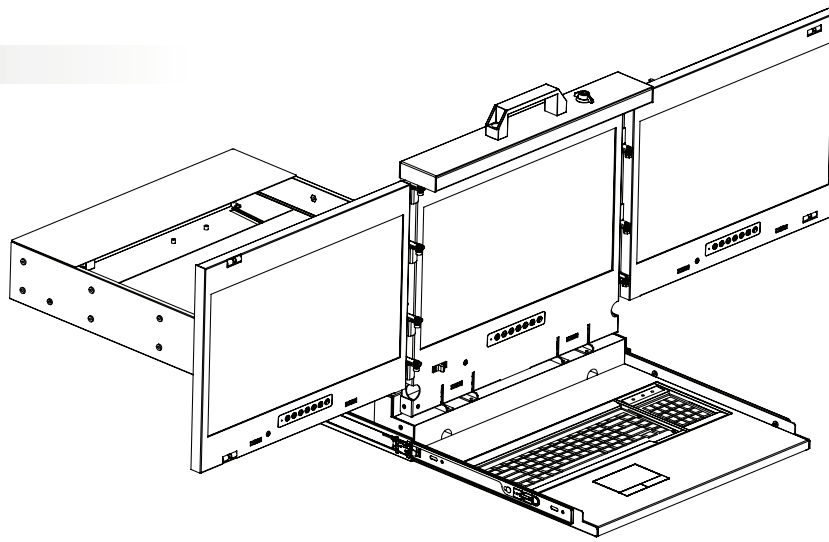

## Front View

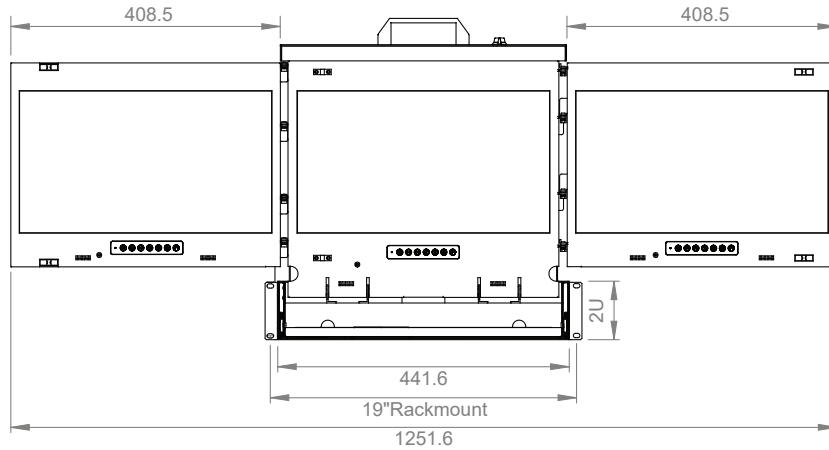

## Side View

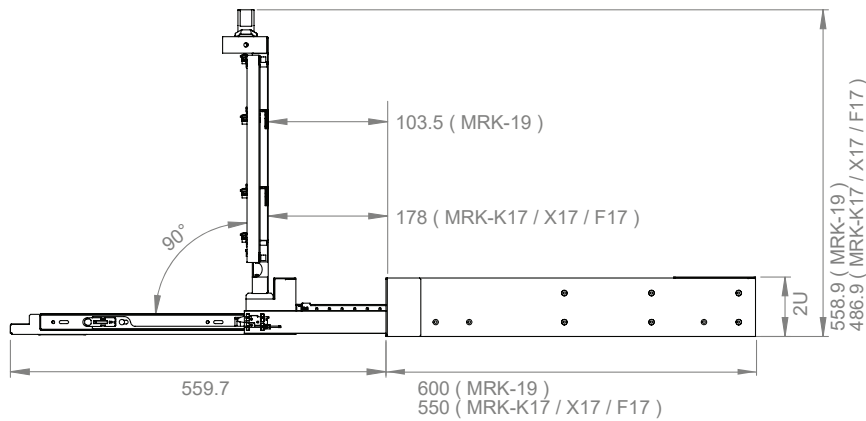

## Rear View

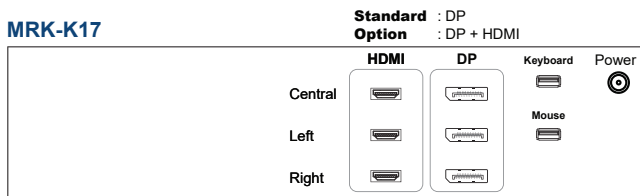

### Add-on USB Selector

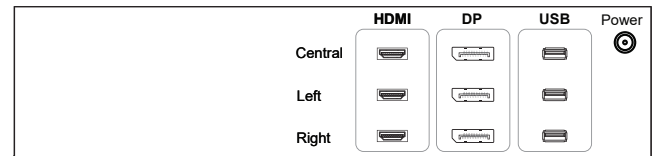

## MRK-F17

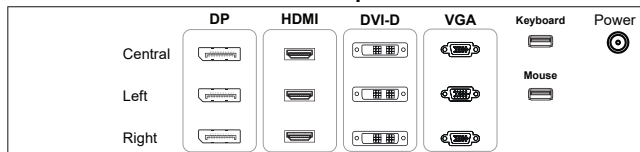

### Add-on USB Selector

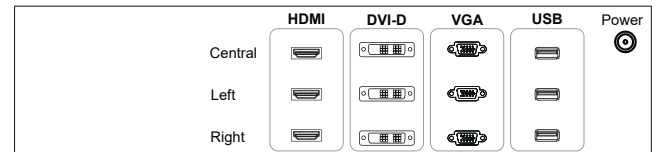

## MRK-X17 / MRK-19

